

R-PQFP Yamaichi Socket Adapter for Texas Instrument MSP430x33xPQ  
 Adapter DProbe430 MQFP100 Yamaichi Socket MSP430x33xPQ  
 Part No.: AKD43033xPQ, (SOMQ100-Y)

Top Connection : Emulator DProbe430

Bottom Connection : R-PQFP/MQFP100 Yamaichi Socket **SOMQ100-Y** for CPU MSP430x33xPQ (must be ordered separately)

**Top View**

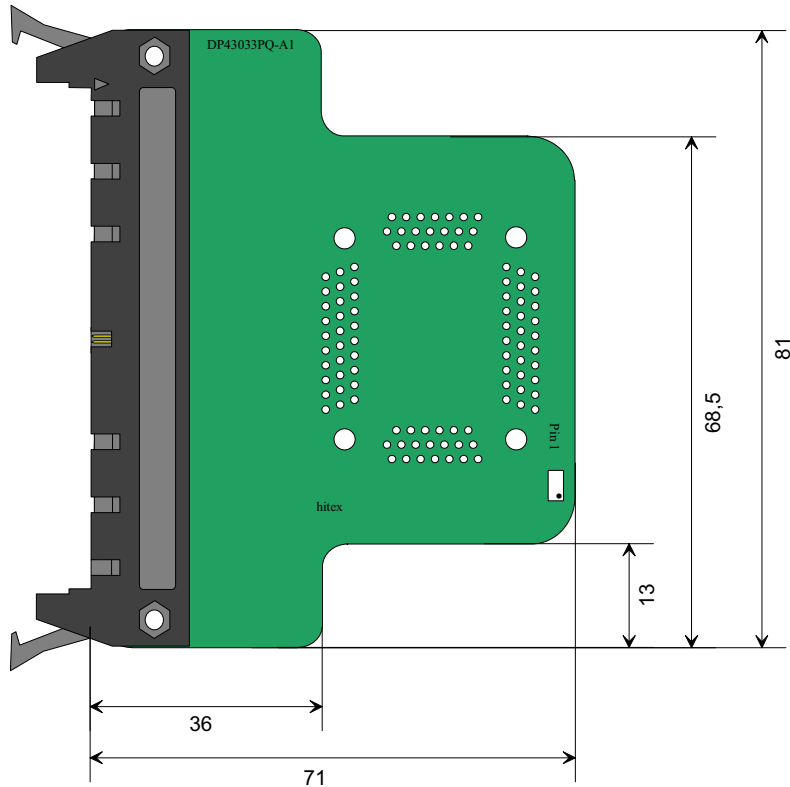

**Side View**

